

Property of INPUT/OUTPUT, INC.

INPUT/OUTPUT, INC.

11104 West Airport Blvd.
Stafford, Texas 77477 USA

THE I/O SYSTEM

TAPE HEADER FORMAT

©Input/Output, Inc., 1995, 1998
All Rights Reserved

September 1998
I/O Part #131015E

I/O SYSTEM ONE® and I/O SYSTEM TWO® are covered by U.S. Patents 4,750,156 and 4,875,166 and corresponding foreign patents.

Document Revision Log	
131015A	Reformatted original document to show all bytes in all the header blocks. Added alternate format for ancillary header block 1. Expanded explanation of descale multiplier. Incorporated formulas for HPE notch. Added explanations for data conversion loss and channel set descriptors.
131015B	Corrected explanations of first timing word and time break window end in trace header. Added external header information. Added document revision log.
131015C	Added 4-digit year and reel number to general header and sensor type to trace header. Eliminated duplicate byte designators. Corrected description of anti-alias filter in scan type header and discussion of aux channel descale multiplier.
131015D	Added definitions to spread type in extended general header. Released in Adobe PDF format.
131015E	Added correct FS values for auxillary channels and a description of the effect of the correlator manual scale factor to the discussion of the descale multiplier.

1. INTRODUCTION

This document describes Revision 1 of the Input/Output implementation of the SEG-D field tape format. The tape record produced by Input/Output Data Acquisition Systems conforms to the SEG-D format explained in Digital Tape Standards, (Society for Exploration Geophysicists, Tulsa, OK, 1980) as amended by SEG-D, Revision 1 (Geophysics, Vol. 59, No. 4, April, 1994).

The format described in this document utilizes the standard header format described in the 1980 document with the addition of the IEEE demultiplexed trace data format. The format of the extended general header is specified by Input/Output.

1.1 OVERVIEW

The tape record consists of two main sections: tape header and trace data. The tape format and the bit position values are shown below.

The tape header is a single ungapped block of data separated from the trace data by a standard interblock gap. The tape header contains the following headers: general header, scan type header, extended header, and (optionally) external header.

For a given record the tape header contains the following information:

- how to unpack the header (general header),
- the general setup for trace hardware (scan type header),
- how to link the channel sets in the scan type header with the associated line/station coordinate system (extended header),
- survey and record event context information (extended header), and
- general instrument setup and filter parameters (extended header).

The trace data contains all the data samples for a record event. Trace data is recorded in demultiplexed format with auxiliary channels first, followed by data channels. Each trace is recorded in a block containing the trace header followed by the trace data. Each trace is separated from other traces by a standard interblock gap.

Unless otherwise stated, parameters in the general, scan type, and trace headers are in packed binary-coded decimal (BCD) format and parameters in the extended header are expressed in binary (BIN) format. In some cases the entire range of possible values are not used. In these cases the description will indicate the valid range of values produced by the system.

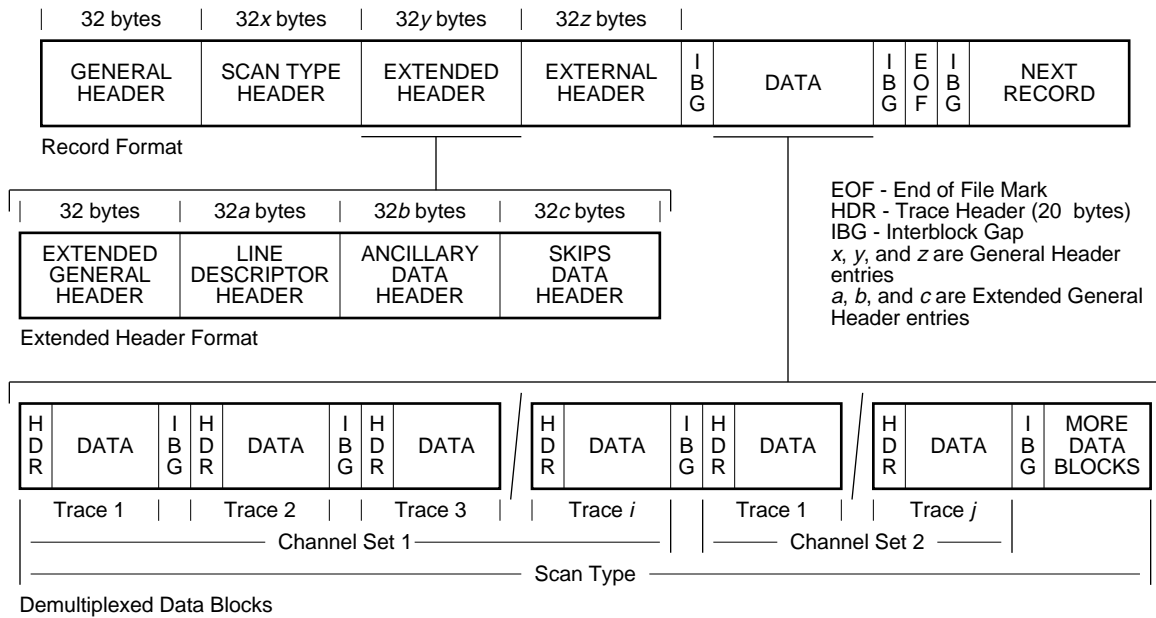

TAPE FORMAT

Bit Number	P	0	1	2	3	4	5	6	7	
BCD Value	MSD	8	4	2	1	8	4	2	1	LSD
Binary Value	MSB	128	64	32	16	8	4	2	1	LSB

BIT POSITION VALUES

2. GENERAL HEADER

The general header contains identifying information specific to the record event and values used to unpack the remainder of the header. The format of the general header is shown below.

Note that all data from Input/Output Data Acquisition Systems is recorded in demultiplexed format, only one scan type is used, and there is no sample skew.

0	1	2	3	4	5	6	7
F ₁	F ₁	F ₁	F ₁	F ₂	F ₂	F ₂	F ₂
F ₃	F ₃	F ₃	F ₃	F ₄	F ₄	F ₄	F ₄
Y ₁	Y ₁	Y ₁	Y ₁	Y ₂	Y ₂	Y ₂	Y ₂
Y ₃	Y ₃	Y ₃	Y ₃	Y ₄	Y ₄	Y ₄	Y ₄
KYR ₁	KYR ₁	KYR ₁	KYR ₁	KYR ₂	KYR ₂	KYR ₂	KYR ₂
KYR ₃	KYR ₃	KYR ₃	KYR ₃	KYR ₄	KYR ₄	KYR ₄	KYR ₄
K ₅	K ₅	K ₅	K ₅	K ₆	K ₆	K ₆	K ₆
KRN ₁	KRN ₁	KRN ₁	KRN ₁	KRN ₂	KRN ₂	KRN ₂	KRN ₂
KRN ₃	KRN ₃	KRN ₃	KRN ₃	KRN ₄	KRN ₄	KRN ₄	KRN ₄
KRN ₅	KRN ₅	KRN ₅	KRN ₅	KRN ₆	KRN ₆	KRN ₆	KRN ₆
YR ₁	YR ₁	YR ₁	YR ₁	YR ₂	YR ₂	YR ₂	YR ₂
0	0	0	0	DY ₁	DY ₁	DY ₁	DY ₁
DY ₂	DY ₂	DY ₂	DY ₂	DY ₃	DY ₃	DY ₃	DY ₃
H ₁	H ₁	H ₁	H ₁	H ₂	H ₂	H ₂	H ₂
MI ₁	MI ₁	MI ₁	MI ₁	MI ₂	MI ₂	MI ₂	MI ₂
SE ₁	SE ₁	SE ₁	SE ₁	SE ₂	SE ₂	SE ₂	SE ₂
M ₁	M ₁	M ₁	M ₁	M ₂	M ₂	M ₂	M ₂
M ₃	M ₃	M ₃	M ₃	M ₄	M ₄	M ₄	M ₄
M ₅	M ₅	M ₅	M ₅	M ₆	M ₆	M ₆	M ₆
B ₁	B ₁	B ₁	B ₁	B ₂	B ₂	B ₂	B ₂
B ₃	B ₃	B ₃	B ₃	B ₄	B ₄	B ₄	B ₄
B ₅	B ₅	B ₅	B ₅	B ₆	B ₆	B ₆	B ₆
I ₃	I ₂	I ₁	I ₀	I ₁	I ₂	I ₃	I ₄
P	P	P	P	S/BX ₃	S/BX ₂	S/BX ₁	S/BX ₀
S/B ₇	S/B ₆	S/B ₅	S/B ₄	S/B ₃	S/B ₂	S/B ₁	S/B ₀
Z	Z	Z	Z	R ₁	R ₁	R ₁	R ₁
R ₂	R ₂	R ₂	R ₂	R ₃	R ₃	R ₃	R ₃
ST/R ₁	ST/R ₁	ST/R ₁	ST/R ₁	ST/R ₂	ST/R ₂	ST/R ₂	ST/R ₂
CS ₁	CS ₁	CS ₁	CS ₁	CS ₂	CS ₂	CS ₂	CS ₂
SK ₁	SK ₁	SK ₁	SK ₁	SK ₂	SK ₂	SK ₂	SK ₂
EC ₁	EC ₁	EC ₁	EC ₁	EC ₂	EC ₂	EC ₂	EC ₂
EX ₁	EX ₁	EX ₁	EX ₁	EX ₂	EX ₂	EX ₂	EX ₂

- F File number (0000-9999).
- 1 Y Format code. Valid values:
8015 20-bit binary demultiplexed
SEG-D 2 1/2 Byte
- 2 8048 32-bit hexadecimal demultiplexed
SEG-D 4 Byte
- 3 8058 32-bit IEEE demultiplexed
SEG-D IEEE
- 4
- 5 KYR Year (four BCD digits). (Prior to Software Release 8.0, value was 0102.)
- 6
- 7 K₅₋₆ General constants. Not used.
- 8 KRN Reel number (000000-999999). (Prior to Software Release 8.0, value was 040506.)
- 9 YR Last two digits of year (00-99).
DY Julian day (001-366).
- 10 H Hour of day, Greenwich Mean Time (00-23).
MI Minute of hour (00-59).
SE Second of minute (00-59).
- 11
- 12 M₁₋₂ Manufacturer's code. Always 18 (0001 1000).
M₃₋₅ Manufacturer's serial number (0000-9999).
This is the serial number of the System Control Module (SCM) backplane.
- 13
- 14 B Bytes per scan. Always 0.
- 15 I Base scan interval (milliseconds). Valid values:
0000 1000 1/2 msec
0001 0000 1 msec
0010 0000 2 msec
0100 0000 4 msec
- 16
- 17
- 18 P Polarity. Always 0 (untested).
- 19
- 20 S/BX Scans per block exponent. Always 0.
S/B Scans per block. Always 0.
- 21 Z Record type. Valid values:
0010 Test record
1000 Normal record
0001 Other
- 22
- 23
- 24 R Record length in tenths of seconds. Value can range from .5 to 99.5 in .5 second increments. Since records are made in binary seconds, actual record time is 1.024 seconds of data per second. This represents a range of from .512 to 101.888 seconds.
- 25
- 26
- 27 ST/R Scan types per record. Always 1.
- 28 CS Channel sets per scan type (01-99).
- 29 SK Skew blocks. Always 0.
- 30 EC Extended header length (04-99). Number of 32 byte blocks.
- 31
- 32 EX External header length (00-99). Number of 32 byte blocks.

GENERAL HEADER

3. SCAN TYPE HEADER

Since all data for one record is collected at the same data rate, with the same filter and notch settings, and with no skew data, the scan type header is simply a list of channel descriptors. The scan type header may contain from 1 to 99 channel set descriptors. The format of the scan type header is shown below.

Since I/O Data Acquisition Systems support a more complex filter setup than the original SEG-D scan type header, low cut filter frequency and slope and notch filter frequencies are set to zero. The values for system filters may be found in the ancillary header block of the extended header.

In a multiline configuration, a channel set may extend over more than one line. This is explained in section 10.

0	1	2	3	4	5	6	7
ST ₁	ST ₁	ST ₁	ST ₁	ST ₂	ST ₂	ST ₂	ST ₂
CN ₁	CN ₁	CN ₁	CN ₁	CN ₂	CN ₂	CN ₂	CN ₂
TF ₁₆	TF ₁₅	TF ₁₄	TF ₁₃	TF ₁₂	TF ₁₁	TF ₁₀	TF ₉
TF ₈	TF ₇	TF ₆	TF ₅	TF ₄	TF ₃	TF ₂	TF ₁
TE ₁₆	TE ₁₅	TE ₁₄	TE ₁₃	TE ₁₂	TE ₁₁	TE ₁₀	TE ₉
TE ₈	TE ₇	TE ₆	TE ₅	TE ₄	TE ₃	TE ₂	TE ₁
0	0	0	0	0	0	0	0
MP _S	MP ₄	MP ₃	MP ₂	MP ₁	MP ₀	MP ₋₁	MP ₋₂
C/S ₁	C/S ₁	C/S ₁	C/S ₁	C/S ₂	C/S ₂	C/S ₂	C/S ₂
C/S ₃	C/S ₃	C/S ₃	C/S ₃	C/S ₄	C/S ₄	C/S ₄	C/S ₄
C ₁	C ₁	C ₁	C ₁	0	0	0	0
S/C	S/C	S/C	S/C	J	J	J	J
AF ₁	AF ₁	AF ₁	AF ₁	AF ₂	AF ₂	AF ₂	AF ₂
AF ₃	AF ₃	AF ₃	AF ₃	AF ₄	AF ₄	AF ₄	AF ₄
0	0	0	0	AS ₁	AS ₁	AS ₁	AS ₁
AS ₂	AS ₂	AS ₂	AS ₂	AS ₃	AS ₃	AS ₃	AS ₃
LC ₁	LC ₁	LC ₁	LC ₁	LC ₂	LC ₂	LC ₂	LC ₂
LC ₃	LC ₃	LC ₃	LC ₃	LC ₄	LC ₄	LC ₄	LC ₄
0	0	0	0	LS ₁	LS ₁	LS ₁	LS ₁
LS ₂	LS ₂	LS ₂	LS ₂	LS ₃	LS ₃	LS ₃	LS ₃
NT ₁	NT ₁	NT ₁	NT ₁	NT ₂	NT ₂	NT ₂	NT ₂
NT ₃	NT ₃	NT ₃	NT ₃	NT ₄	NT ₄	NT ₄	NT ₄
NT ₁	NT ₁	NT ₁	NT ₁	NT ₂	NT ₂	NT ₂	NT ₂
NT ₃	NT ₃	NT ₃	NT ₃	NT ₄	NT ₄	NT ₄	NT ₄
NT ₁	NT ₁	NT ₁	NT ₁	NT ₂	NT ₂	NT ₂	NT ₂
NT ₃	NT ₃	NT ₃	NT ₃	NT ₄	NT ₄	NT ₄	NT ₄
0	0	0	0	0	0	0	0
0	0	0	0	0	0	0	0
0	0	0	0	0	0	0	0
0	0	0	0	0	0	0	0
0	0	0	0	0	0	0	0
0	0	0	0	0	0	0	0
0	0	0	0	0	0	0	0

- 1 ST Scan type number. Always 1.
- 2 CN Channel set number (01-99).
- 3 TF Channel set start time. Always 0.
- 4 TE Channel set end time. The number of 2msec intervals in the record length.
- 5 MP Descale multiplier. The exponent of the base 2 multiplier used to descale the data. See section 7 for an explanation of the descale multiplier.
- 6 C/S Number of channels in this channel set (1-9999).
- 7 C Channel type. Valid values:
 0000 Unused (zeroed data)
 0001 Seismic data
 0010 Time break
 0011 Up hole
 0100 Water break
 0101 Time counter (100 Hz signal)
 0110 External data
 0111 Other
 1000 Vibroseis pilot, unfiltered
 1001 Vibroseis pilot, filtered
- 8 S/C Subscans in base scan. Always 0.
- 9 J Channel gain control method. Valid values:
 0011 Fixed gain (auxiliary channels in all systems and seismic data in the I/O SYSTEM TWO).
 1001 IFP gain control (seismic data in the I/O SYSTEM ONE).
- 10 AF Alias filter frequency in Hertz (0-9999).
- 11 AS Alias filter slope in dB per octave (0-999).
- 12 LC Low-cut filter frequency. Always 0. See the ancillary data header in the extended header.
- 13 LS Low-cut filter slope. Always 0. See the ancillary data header in the extended header.
- 14 NT Notch frequency (three notches). Always 0. See the ancillary data header in the extended header.
- 15
- 16
- 17
- 18
- 19
- 20
- 21
- 22
- 23
- 24
- 25
- 26
- 27
- 28
- 29
- 30
- 31
- 32

SCAN TYPE HEADER

4. EXTENDED HEADER

This header may consist of from 4 to 99 blocks and contains: the extended general header, describing the other header sections in the extended header; the line descriptor header, describing the seismic line's characteristics; the ancillary data header, describing setups for the record event; and (optionally) the skips header, describing channel skips (fixed gaps) in the record event.

4.1 EXTENDED GENERAL HEADER

The extended general header contains the revision number for the extended header format, the block lengths of the other sections of the extended header, and some parameters not readily classified as ancillary data.

0	1	2	3	4	5	6	7
HR ₁₆	HR ₁₅	HR ₁₄	HR ₁₃	HR ₁₂	HR ₁₁	HR ₁₀	HR ₉
HR ₈	HR ₇	HR ₆	HR ₅	HR ₄	HR ₃	HR ₂	HR ₁
NL ₈	NL ₇	NL ₆	NL ₅	NL ₄	NL ₃	NL ₂	NL ₁
LD ₈	LD ₇	LD ₆	LD ₅	LD ₄	LD ₃	LD ₂	LD ₁
PB ₈	PB ₇	PB ₆	PB ₅	PB ₄	PB ₃	PB ₂	PB ₁
SP ₈	SP ₇	SP ₆	SP ₅	SP ₄	SP ₃	SP ₂	SP ₁
0	0	0	0	0	0	0	0
0	0	0	0	0	0	0	0
0	0	0	0	0	0	0	0
0	0	0	0	0	0	0	0
NAX ₈	NAX ₇	NAX ₆	NAX ₅	NAX ₄	NAX ₃	NAX ₂	NAX ₁
AUXF ₈	AUXF ₇	AUXF ₆	AUXF ₅	AUXF ₄	AUXF ₃	AUXF ₂	AUXF ₁
AUXL ₈	AUXL ₇	AUXL ₆	AUXL ₅	AUXL ₄	AUXL ₃	AUXL ₂	AUXL ₁
0	0	0	0	0	0	0	0
0	0	0	0	0	0	0	0
0	0	0	0	0	0	0	0
0	0	0	0	0	0	0	0
FM ₈	FM ₇	FM ₆	FM ₅	FM ₄	FM ₃	FM ₂	FM ₁
LT ₁₆	LT ₁₅	LT ₁₄	LT ₁₃	LT ₁₂	LT ₁₁	LT ₁₀	LT ₉
LT ₈	LT ₇	LT ₆	LT ₅	LT ₄	LT ₃	LT ₂	LT ₁
RC ₁₆	RC ₁₅	RC ₁₄	RC ₁₃	RC ₁₂	RC ₁₁	RC ₁₀	RC ₉
RC ₈	RC ₇	RC ₆	RC ₅	RC ₄	RC ₃	RC ₂	RC ₁
DL ₁₆	DL ₁₅	DL ₁₄	DL ₁₃	DL ₁₂	DL ₁₁	DL ₁₀	DL ₉
DL ₈	DL ₇	DL ₆	DL ₅	DL ₄	DL ₃	DL ₂	DL ₁
DF ₁₆	DF ₁₅	DF ₁₄	DF ₁₃	DF ₁₂	DF ₁₁	DF ₁₀	DF ₉
DF ₈	DF ₇	DF ₆	DF ₅	DF ₄	DF ₃	DF ₂	DF ₁
SPT ₈	SPT ₇	SPT ₆	SPT ₅	SPT ₄	SPT ₃	SPT ₂	SPT ₁
0	0	0	0	0	0	0	0
0	0	0	0	0	0	0	0
0	0	0	0	0	0	0	0
0	0	0	0	0	0	0	0
0	0	0	0	0	0	0	0

- 1 HR Revision ID. Always 1. (The header revision described in this document is the only version used in the I/O SYSTEM ONE and I/O SYSTEM TWO.)
- 2
- 3 NL Number of lines (0-255).
- 4 LD Number of 32 byte blocks for line descriptor header (1-96).
- 5 PB Number of 32 byte blocks for ancillary header. Always 2.
- 6
- 7 SP Number of 32 byte blocks for skips header (0-10).
- 8
- 9 NAX Number of auxillary channels (0-12).
- 10 AUXF First auxillary channel set number (0-1).
- 11 AUXL Last auxillary channel set number (0-12).
- 12 FM Units of measurement: 0 = feet, 1 = meters.
- 13 LT Length of line tap cable in tenths of FM units (10-65000).
- 14 RC Length of field unit cable in tenths of FM units (10-65000).
- 15
- 16 DL Line interval in tenths of FM units (0-65000).
- 17 DF Station interval in tenths of FM units (10-9999).
- 18 SPT Spread type. Valid values:
00h Unspecified
04h Radio system

EXTENDED GENERAL HEADER

4.2 LINE DESCRIPTOR HEADER

The line descriptor header characterizes the line in terms of channel sets, station numbers, energy gap channels, skip gap channels, and bad traces.

The first byte of each line descriptor block contains the number of lines remaining to be described, including the

ones in that block. Up to two lines may be described per block. Bytes 3 through 15 describe a line. If a second line is described, bytes 17 through 29 will describe it using the same format as bytes 3 through 15. The number of line descriptor header blocks is defined in the extended general header.

0	1	2	3	4	5	6	7
LR ₈	LR ₇	LR ₆	LR ₅	LR ₄	LR ₃	LR ₂	LR ₁
0	0	0	0	0	0	0	0
L _S	L ₁₅	L ₁₄	L ₁₃	L ₁₂	L ₁₁	L ₁₀	L ₉
L ₈	L ₇	L ₆	L ₅	L ₄	L ₃	L ₂	L ₁
NC ₈	NC ₇	NC ₆	NC ₅	NC ₄	NC ₃	NC ₂	NC ₁
CS ₈	CS ₇	CS ₆	CS ₅	CS ₄	CS ₃	CS ₂	CS ₁
LSF _S	LSF ₁₅	LSF ₁₄	LSF ₁₃	LSF ₁₂	LSF ₁₁	LSF ₁₀	LSF ₉
LSF ₈	LSF ₇	LSF ₆	LSF ₅	LSF ₄	LSF ₃	LSF ₂	LSF ₁
LSL _S	LSL ₁₅	LSL ₁₄	LSL ₁₃	LSL ₁₂	LSL ₁₁	LSL ₁₀	LSL ₉
LSL ₈	LSL ₇	LSL ₆	LSL ₅	LSL ₄	LSL ₃	LSL ₂	LSL ₁
GS _S	GS ₁₅	GS ₁₄	GS ₁₃	GS ₁₂	GS ₁₁	GS ₁₀	GS ₉
GS ₈	GS ₇	GS ₆	GS ₅	GS ₄	GS ₃	GS ₂	GS ₁
NG ₈	NG ₇	NG ₆	NG ₅	NG ₄	NG ₃	NG ₂	NG ₁
NS ₈	NS ₇	NS ₆	NS ₅	NS ₄	NS ₃	NS ₂	NS ₁
NB ₈	NB ₇	NB ₆	NB ₅	NB ₄	NB ₃	NB ₂	NB ₁
0	0	0	0	0	0	0	0
L _S	L ₁₅	L ₁₄	L ₁₃	L ₁₂	L ₁₁	L ₁₀	L ₉
L ₈	L ₇	L ₆	L ₅	L ₄	L ₃	L ₂	L ₁
NC ₈	NC ₇	NC ₆	NC ₅	NC ₄	NC ₃	NC ₂	NC ₁
CS ₈	CS ₇	CS ₆	CS ₅	CS ₄	CS ₃	CS ₂	CS ₁
LSF _S	LSF ₁₅	LSF ₁₄	LSF ₁₃	LSF ₁₂	LSF ₁₁	LSF ₁₀	LSF ₉
LSF ₈	LSF ₇	LSF ₆	LSF ₅	LSF ₄	LSF ₃	LSF ₂	LSF ₁
LSL _S	LSL ₁₅	LSL ₁₄	LSL ₁₃	LSL ₁₂	LSL ₁₁	LSL ₁₀	LSL ₉
LSL ₈	LSL ₇	LSL ₆	LSL ₅	LSL ₄	LSL ₃	LSL ₂	LSL ₁
GS _S	GS ₁₅	GS ₁₄	GS ₁₃	GS ₁₂	GS ₁₁	GS ₁₀	GS ₉
GS ₈	GS ₇	GS ₆	GS ₅	GS ₄	GS ₃	GS ₂	GS ₁
NG ₈	NG ₇	NG ₆	NG ₅	NG ₄	NG ₃	NG ₂	NG ₁
NS ₈	NS ₇	NS ₆	NS ₅	NS ₄	NS ₃	NS ₂	NS ₁
NB ₈	NB ₇	NB ₆	NB ₅	NB ₄	NB ₃	NB ₂	NB ₁
0	0	0	0	0	0	0	0
0	0	0	0	0	0	0	0
0	0	0	0	0	0	0	0

- 1 LR Number of line descriptors remaining, including the ones in this block (1-192).
- 2 L Line number (two's complement, signed binary) (from -32000 to +32000).
- 3 NC Number of channel sets on this line (1-99).
- 4 CS Starting channel set number (1-99).
- 6 LSF First station of line on tape (two's complement, signed binary) (from -32000 to +32000).
- 7 LSL Last station of line on tape (two's complement, signed binary) (from -32000 to +32000).
- 9 GS Energy gap station number (lowest numbered station in the energy gap) (two's complement, signed binary) (from -32000 to +32000).
- 10 NG Number of stations in the energy gap (0-255). If NG=0, ignore GS.
- 12 NS Number of fixed gap descriptors created for this line (0-50).
- 13 NB Number of bad trace descriptors created for this line. Always 0.

LINE DESCRIPTOR HEADER

4.3 ANCILLARY DATA HEADER

Instrumentation setup, source, and survey data are put in the ancillary header. The ancillary header contains parameters for the HPE notch, the spectral shaping, and up to three low cut filters.

Depending upon the type of HPE notch selected, there are two formats of ancillary data header block 1. The type of HPE notch is specified by the value in byte 24 of ancillary data header block 1. If powerline HPE is used, the value will be 0 or 1 and the format shown on this page is the one to use. If special fixed frequency notches are used, the value is 2 and the format shown on the next page is used.

0	1	2	3	4	5	6	7
HPES ₃₂	HPES ₃₁	HPES ₃₀	HPES ₂₉	HPES ₂₈	HPES ₂₇	HPES ₂₆	HPES ₂₅
HPES ₂₄	HPES ₂₃	HPES ₂₂	HPES ₂₁	HPES ₂₀	HPES ₁₉	HPES ₁₈	HPES ₁₇
HPES ₁₆	HPES ₁₅	HPES ₁₄	HPES ₁₃	HPES ₁₂	HPES ₁₁	HPES ₁₀	HPES ₉
HPES ₈	HPES ₇	HPES ₆	HPES ₅	HPES ₄	HPES ₃	HPES ₂	HPES ₁
HPEE ₃₂	HPEE ₃₁	HPEE ₃₀	HPEE ₂₉	HPEE ₂₈	HPEE ₂₇	HPEE ₂₆	HPEE ₂₅
HPEE ₂₄	HPEE ₂₃	HPEE ₂₂	HPEE ₂₁	HPEE ₂₀	HPEE ₁₉	HPEE ₁₈	HPEE ₁₇
HPEE ₁₆	HPEE ₁₅	HPEE ₁₄	HPEE ₁₃	HPEE ₁₂	HPEE ₁₁	HPEE ₁₀	HPEE ₉
HPEE ₈	HPEE ₇	HPEE ₆	HPEE ₅	HPEE ₄	HPEE ₃	HPEE ₂	HPEE ₁
MXA ₈	MXA ₇	MXA ₆	MXA ₅	MXA ₄	MXA ₃	MXA ₂	MXA ₁
MXB ₈	MXB ₇	MXB ₆	MXB ₅	MXB ₄	MXB ₃	MXB ₂	MXB ₁
MXC ₈	MXC ₇	MXC ₆	MXC ₅	MXC ₄	MXC ₃	MXC ₂	MXC ₁
MXD ₈	MXD ₇	MXD ₆	MXD ₅	MXD ₄	MXD ₃	MXD ₂	MXD ₁
MXE ₈	MXE ₇	MXE ₆	MXE ₅	MXE ₄	MXE ₃	MXE ₂	MXE ₁
NWA ₁₆	NWA ₁₅	NWA ₁₄	NWA ₁₃	NWA ₁₂	NWA ₁₁	NWA ₁₀	NWA ₉
NWA ₈	NWA ₇	NWA ₆	NWA ₅	NWA ₄	NWA ₃	NWA ₂	NWA ₁
NWB ₁₆	NWB ₁₅	NWB ₁₄	NWB ₁₃	NWB ₁₂	NWB ₁₁	NWB ₁₀	NWB ₉
NWB ₈	NWB ₇	NWB ₆	NWB ₅	NWB ₄	NWB ₃	NWB ₂	NWB ₁
NWC ₁₆	NWC ₁₅	NWC ₁₄	NWC ₁₃	NWC ₁₂	NWC ₁₁	NWC ₁₀	NWC ₉
NWC ₈	NWC ₇	NWC ₆	NWC ₅	NWC ₄	NWC ₃	NWC ₂	NWC ₁
NWD ₁₆	NWD ₁₅	NWD ₁₄	NWD ₁₃	NWD ₁₂	NWD ₁₁	NWD ₁₀	NWD ₉
NWD ₈	NWD ₇	NWD ₆	NWD ₅	NWD ₄	NWD ₃	NWD ₂	NWD ₁
NWE ₁₆	NWE ₁₅	NWE ₁₄	NWE ₁₃	NWE ₁₂	NWE ₁₁	NWE ₁₀	NWE ₉
NWE ₈	NWE ₇	NWE ₆	NWE ₅	NWE ₄	NWE ₃	NWE ₂	NWE ₁
FA ₈	FA ₇	FA ₆	FA ₅	FA ₄	FA ₃	FA ₂	FA ₁
TC ₁₆	TC ₁₅	TC ₁₄	TC ₁₃	TC ₁₂	TC ₁₁	TC ₁₀	TC ₉
TC ₈	TC ₇	TC ₆	TC ₅	TC ₄	TC ₃	TC ₂	TC ₁
LCA ₁₆	LCA ₁₅	LCA ₁₄	LCA ₁₃	LCA ₁₂	LCA ₁₁	LCA ₁₀	LCA ₉
LCA ₈	LCA ₇	LCA ₆	LCA ₅	LCA ₄	LCA ₃	LCA ₂	LCA ₁
LAA ₈	LAA ₇	LAA ₆	LAA ₅	LAA ₄	LAA ₃	LAA ₂	LAA ₁
LCB ₁₆	LCB ₁₅	LCB ₁₄	LCB ₁₃	LCB ₁₂	LCB ₁₁	LCB ₁₀	LCB ₉
LCB ₈	LCB ₇	LCB ₆	LCB ₅	LCB ₄	LCB ₃	LCB ₂	LCB ₁
LAB ₈	LAB ₇	LAB ₆	LAB ₅	LAB ₄	LAB ₃	LAB ₂	LAB ₁

- 1 HPES HPE base frequency (in microhertz) at start of record.
- 2 HPEE HPE base frequency (in microhertz) at end of record.
- 3
- 4 MXA Harmonic multiplier. This value is six times to the value entered at the OCM. Thus, a value of 12 indicates the second harmonic.
- 5 MXE If MXA to MXE are all 0, then ignore HPES, HPEE, and NWA to NWE. If any value in MXA to MXE is not 0, then HPES and HPEE are valid along with the corresponding NWn value.
- 6
- 7
- 8 NWA Notch bandwidth. This is an integer value that to is used in the notch equations explained in section 7.
- 9 NWE
- 10 FA HPE mode. Valid values:
0 Tracking mode powerline HPE
1 Fixed mode powerline HPE
(If this value is 2, use the format on the next page to decode ancillary data header 1.)
- 11
- 12
- 13 TC HPE averaging time constant. In fixed mode, always 0. In tracking mode, always 1000.
- 14
- 15 LCA Low cut A frequency (in tenths of hertz). If LCA=0, then ignore LAA (notch is bypassed).
- 16 LAA Low cut A attenuator value (dB).
- 17 LCB Low cut B frequency (in tenths of hertz). If LCB=0, then ignore LAB (notch is bypassed).
- 18 LAB Low cut B attenuator value (dB).
- 19
- 20
- 21
- 22
- 23
- 24
- 25
- 26
- 27
- 28
- 29
- 30
- 31
- 32

**ANCILLARY DATA HEADER BLOCK 1
(Powerline Mode)**

0	1	2	3	4	5	6	7
NFA ₁₆	NFA ₁₅	NFA ₁₄	NFA ₁₃	NFA ₁₂	NFA ₁₁	NFA ₁₀	NFA ₉
NFA ₈	NFA ₇	NFA ₆	NFA ₅	NFA ₄	NFA ₃	NFA ₂	NFA ₁
NFB ₁₆	NFB ₁₅	NFB ₁₄	NFB ₁₃	NFB ₁₂	NFB ₁₁	NFB ₁₀	NFB ₉
NFB ₈	NFB ₇	NFB ₆	NFB ₅	NFB ₄	NFB ₃	NFB ₂	NFB ₁
NFC ₁₆	NFC ₁₅	NFC ₁₄	NFC ₁₃	NFC ₁₂	NFC ₁₁	NFC ₁₀	NFC ₉
NFC ₈	NFC ₇	NFC ₆	NFC ₅	NFC ₄	NFC ₃	NFC ₂	NFC ₁
NFD ₁₆	NFD ₁₅	NFD ₁₄	NFD ₁₃	NFD ₁₂	NFD ₁₁	NFD ₁₀	NFD ₉
NFD ₈	NFD ₇	NFD ₆	NFD ₅	NFD ₄	NFD ₃	NFD ₂	NFD ₁
NFE ₁₆	NFE ₁₅	NFE ₁₄	NFE ₁₃	NFE ₁₂	NFE ₁₁	NFE ₁₀	NFE ₉
NFE ₈	NFE ₇	NFE ₆	NFE ₅	NFE ₄	NFE ₃	NFE ₂	NFE ₁
0	0	0	0	0	0	0	0
0	0	0	0	0	0	0	0
0	0	0	0	0	0	0	0
NWA ₁₆	NWA ₁₅	NWA ₁₄	NWA ₁₃	NWA ₁₂	NWA ₁₁	NWA ₁₀	NWA ₉
NWA ₈	NWA ₇	NWA ₆	NWA ₅	NWA ₄	NWA ₃	NWA ₂	NWA ₁
NWB ₁₆	NWB ₁₅	NWB ₁₄	NWB ₁₃	NWB ₁₂	NWB ₁₁	NWB ₁₀	NWB ₉
NWB ₈	NWB ₇	NWB ₆	NWB ₅	NWB ₄	NWB ₃	NWB ₂	NWB ₁
NWC ₁₆	NWC ₁₅	NWC ₁₄	NWC ₁₃	NWC ₁₂	NWC ₁₁	NWC ₁₀	NWC ₉
NWC ₈	NWC ₇	NWC ₆	NWC ₅	NWC ₄	NWC ₃	NWC ₂	NWC ₁
NWD ₁₆	NWD ₁₅	NWD ₁₄	NWD ₁₃	NWD ₁₂	NWD ₁₁	NWD ₁₀	NWD ₉
NWD ₈	NWD ₇	NWD ₆	NWD ₅	NWD ₄	NWD ₃	NWD ₂	NWD ₁
NWE ₁₆	NWE ₁₅	NWE ₁₄	NWE ₁₃	NWE ₁₂	NWE ₁₁	NWE ₁₀	NWE ₉
NWE ₈	NWE ₇	NWE ₆	NWE ₅	NWE ₄	NWE ₃	NWE ₂	NWE ₁
FA ₈	FA ₇	FA ₆	FA ₅	FA ₄	FA ₃	FA ₂	FA ₁
0	0	0	0	0	0	0	0
0	0	0	0	0	0	0	0
LCA ₁₆	LCA ₁₅	LCA ₁₄	LCA ₁₃	LCA ₁₂	LCA ₁₁	LCA ₁₀	LCA ₉
LCA ₈	LCA ₇	LCA ₆	LCA ₅	LCA ₄	LCA ₃	LCA ₂	LCA ₁
LAA ₈	LAA ₇	LAA ₆	LAA ₅	LAA ₄	LAA ₃	LAA ₂	LAA ₁
LCB ₁₆	LCB ₁₅	LCB ₁₄	LCB ₁₃	LCB ₁₂	LCB ₁₁	LCB ₁₀	LCB ₉
LCB ₈	LCB ₇	LCB ₆	LCB ₅	LCB ₄	LCB ₃	LCB ₂	LCB ₁
LAB ₈	LAB ₇	LAB ₆	LAB ₅	LAB ₄	LAB ₃	LAB ₂	LAB ₁

- 1 NFA Notch frequency (in hundredths of hertz) for each to special fixed frequency HPE notch (1-42000).
- 2 NFE If NFA to NFE are all 0, then ignore NWA to NWE. If any value in NFA to NFE is not 0, then the corresponding NWN value is valid.
- 3
- 4 NWA Notch bandwidth. This is an integer value that is used in the notch equations explained in section 7.
- 5 NWE
- 6 FA HPE mode. Valid values:
2 Special fixed frequency mode HPE
- 7 (If this value is 0 or 1, use the format on the previous page to decode ancillary data header 1.)
- 8
- 9 LCA Low cut A frequency (in tenths of hertz). If LCA=0, then ignore LAA (notch is bypassed).
- 10 LAA Low cut A attenuator value (dB).
- 11 LCB Low cut B frequency (in tenths of hertz). If LCB=0, then ignore LAB (notch is bypassed).
- 12
- 13 LAB Low cut B attenuator value (dB).
- 14
- 15
- 16
- 17
- 18
- 19
- 20
- 21
- 22
- 23
- 24
- 25
- 26
- 27
- 28
- 29
- 30
- 31
- 32

ANCILLARY DATA HEADER BLOCK 1
(Special Fixed Frequency Mode)

Shot point coordinates recorded by the system are based on the receiver line and station coordinates. The line and station number offsets represent the relative position of the shot between the given line/station and the next adjacent higher numbered line/station.

0	1	2	3	4	5	6	7
LCC ₁₆	LCC ₁₅	LCC ₁₄	LCC ₁₃	LCC ₁₂	LCC ₁₁	LCC ₁₀	LCC ₉
LCC ₈	LCC ₇	LCC ₆	LCC ₅	LCC ₄	LCC ₃	LCC ₂	LCC ₁
SHL ₈	SHL ₇	SHL ₆	SHL ₅	SHL ₄	SHL ₃	SHL ₂	SHL ₁
SHF ₈	SHF ₇	SHF ₆	SHF ₅	SHF ₄	SHF ₃	SHF ₂	SHF ₁
SL ₅	SL ₁₅	SL ₁₄	SL ₁₃	SL ₁₂	SL ₁₁	SL ₁₀	SL ₉
SL ₈	SL ₇	SL ₆	SL ₅	SL ₄	SL ₃	SL ₂	SL ₁
SS ₅	SS ₁₅	SS ₁₄	SS ₁₃	SS ₁₂	SS ₁₁	SS ₁₀	SS ₉
SS ₈	SS ₇	SS ₆	SS ₅	SS ₄	SS ₃	SS ₂	SS ₁
LF ₈	LF ₇	LF ₆	LF ₅	LF ₄	LF ₃	LF ₂	LF ₁
SF ₈	SF ₇	SF ₆	SF ₅	SF ₄	SF ₃	SF ₂	SF ₁
NC ₁₆	NC ₁₅	NC ₁₄	NC ₁₃	NC ₁₂	NC ₁₁	NC ₁₀	NC ₉
NC ₈	NC ₇	NC ₆	NC ₅	NC ₄	NC ₃	NC ₂	NC ₁
NR ₈	NR ₇	NR ₆	NR ₅	NR ₄	NR ₃	NR ₂	NR ₁
STY ₈	STY ₇	STY ₆	STY ₅	STY ₄	STY ₃	STY ₂	STY ₁
SWL ₁₆	SWL ₁₅	SWL ₁₄	SWL ₁₃	SWL ₁₂	SWL ₁₁	SWL ₁₀	SWL ₉
SWL ₈	SWL ₇	SWL ₆	SWL ₅	SWL ₄	SWL ₃	SWL ₂	SWL ₁
NST ₁₆	NST ₁₅	NST ₁₄	NST ₁₃	NST ₁₂	NST ₁₁	NST ₁₀	NST ₉
NST ₈	NST ₇	NST ₆	NST ₅	NST ₄	NST ₃	NST ₂	NST ₁
SFS ₁₆	SFS ₁₅	SFS ₁₄	SFS ₁₃	SFS ₁₂	SFS ₁₁	SFS ₁₀	SFS ₉
SFS ₈	SFS ₇	SFS ₆	SFS ₅	SFS ₄	SFS ₃	SFS ₂	SFS ₁
SFE ₁₆	SFE ₁₅	SFE ₁₄	SFE ₁₃	SFE ₁₂	SFE ₁₁	SFE ₁₀	SFE ₉
SFE ₈	SFE ₇	SFE ₆	SFE ₅	SFE ₄	SFE ₃	SFE ₂	SFE ₁
STLS ₁₆	STLS ₁₅	STLS ₁₄	STLS ₁₃	STLS ₁₂	STLS ₁₁	STLS ₁₀	STLS ₉
STLS ₈	STLS ₇	STLS ₆	STLS ₅	STLS ₄	STLS ₃	STLS ₂	STLS ₁
STLE ₁₆	STLE ₁₅	STLE ₁₄	STLE ₁₃	STLE ₁₂	STLE ₁₁	STLE ₁₀	STLE ₉
STLE ₈	STLE ₇	STLE ₆	STLE ₅	STLE ₄	STLE ₃	STLE ₂	STLE ₁
TTY ₈	TTY ₇	TTY ₆	TTY ₅	TTY ₄	TTY ₃	TTY ₂	TTY ₁
COR ₈	COR ₇	COR ₆	COR ₅	COR ₄	COR ₃	COR ₂	COR ₁
SRT ₈	SRT ₇	SRT ₆	SRT ₅	SRT ₄	SRT ₃	SRT ₂	SRT ₁
0	0	0	0	0	0	0	0
0	0	0	0	0	0	0	0
0	0	0	0	0	0	0	0

- 1 LCC Low cut C frequency (in tenths of hertz). If LCC=0, then notch is bypassed.
- 2 SHL Spectral shaping filter low cut frequency (hertz).
- 3 SHF Spectral shaping filter final gain (dB). If SHF=0, then ignore SHL (bypassed).
- 4 SL Receiver line number of shotpoint (two's complement, signed binary) (-32000 to +32000).
- 6 SS Receiver station number of shotpoint (two's complement, signed binary) (-32000 to +32000).
- 7 LF Shotpoint line offset (in hundredths of the distance between lines) (0-99).
- 9 SF Shotpoint station offset (in hundredths of the distance between stations) (0-99).
- 10 NC Number of channels in this record event (1-8076).
- 12 NR Noise edit code. Valid values:
 0 None 1 Burst
 2 Diversity 3 Burst and diversity
 4 Dual noise algorithm (DNA)
- 13 STY Sweep type code. Valid values:
 0 None 1 Linear
 2 Parabolic 3 Exponential
 4 Other
- 14 SWL Sweep length in tenths of seconds (from 5 to 630 in increments of 5).
- 15 NST Number of energy points in the stack (1-99).
- 17 SFS Starting sweep frequency in tenths of hertz (from 10 to 9990 in increments of 10).
- 18 SFE Ending sweep frequency in tenths of hertz (from 10 to 9990 in increments of 10).
- 19 STLS Length of taper at start of sweep in milliseconds (from 100 to 99900 in increments of 100).
- 20 STLE Length of taper at end of sweep in milliseconds (from 100 to 99900 in increments of 100).
- 21 TTY Taper type. Valid values:
 0 None 1 Linear
 2 Cosine 3 Other
- 22 COR Correlation process. Valid values:
 0 None
 1 Correlate before stack
 2 Correlate after stack
 3 Other
- 23 SRT Source type code. Valid values:
 0 None / test 1 Dynamite
 2 Vibroseis 3 Weightdrop
 4 Airgun 5 Other

ANCILLARY DATA HEADER BLOCK 2

4.4 SKIPS HEADER

Channel skips, or fixed gaps, are station points for which no data was taken, usually because of physical obstructions in the line. Data identifying channel skips are put in this header.

The first byte of each skips header block contains the number of skip gaps remaining to be described, including

the ones in that block. Up to five skip gaps may be described in each block. Bytes 3 through 8 describe a skip. This format may be repeated up to four more times, starting at bytes 9, 15, 21, and 26.

The maximum number of blocks used for skips is ten. The actual number of blocks used is listed in the extended general header.

0	1	2	3	4	5	6	7
NSR ₈	NSR ₇	NSR ₆	NSR ₅	NSR ₄	NSR ₃	NSR ₂	NSR ₁
0	0	0	0	0	0	0	0
SLN _S	SLN ₁₅	SLN ₁₄	SLN ₁₃	SLN ₁₂	SLN ₁₁	SLN ₁₀	SLN ₉
SLN ₈	SLN ₇	SLN ₆	SLN ₅	SLN ₄	SLN ₃	SLN ₂	SLN ₁
SNF _S	SNF ₁₅	SNF ₁₄	SNF ₁₃	SNF ₁₂	SNF ₁₁	SNF ₁₀	SNF ₉
SNF ₈	SNF ₇	SNF ₆	SNF ₅	SNF ₄	SNF ₃	SNF ₂	SNF ₁
NSK ₁₆	NSK ₁₅	NSK ₁₄	NSK ₁₃	NSK ₁₂	NSK ₁₁	NSK ₁₀	NSK ₉
NSK ₈	NSK ₇	NSK ₆	NSK ₅	NSK ₄	NSK ₃	NSK ₂	NSK ₁
SLN _S	SLN ₁₅	SLN ₁₄	SLN ₁₃	SLN ₁₂	SLN ₁₁	SLN ₁₀	SLN ₉
SLN ₈	SLN ₇	SLN ₆	SLN ₅	SLN ₄	SLN ₃	SLN ₂	SLN ₁
SNF _S	SNF ₁₅	SNF ₁₄	SNF ₁₃	SNF ₁₂	SNF ₁₁	SNF ₁₀	SNF ₉
SNF ₈	SNF ₇	SNF ₆	SNF ₅	SNF ₄	SNF ₃	SNF ₂	SNF ₁
NSK ₁₆	NSK ₁₅	NSK ₁₄	NSK ₁₃	NSK ₁₂	NSK ₁₁	NSK ₁₀	NSK ₉
NSK ₈	NSK ₇	NSK ₆	NSK ₅	NSK ₄	NSK ₃	NSK ₂	NSK ₁
SLN _S	SLN ₁₅	SLN ₁₄	SLN ₁₃	SLN ₁₂	SLN ₁₁	SLN ₁₀	SLN ₉
SLN ₈	SLN ₇	SLN ₆	SLN ₅	SLN ₄	SLN ₃	SLN ₂	SLN ₁
SNF _S	SNF ₁₅	SNF ₁₄	SNF ₁₃	SNF ₁₂	SNF ₁₁	SNF ₁₀	SNF ₉
SNF ₈	SNF ₇	SNF ₆	SNF ₅	SNF ₄	SNF ₃	SNF ₂	SNF ₁
NSK ₁₆	NSK ₁₅	NSK ₁₄	NSK ₁₃	NSK ₁₂	NSK ₁₁	NSK ₁₀	NSK ₉
NSK ₈	NSK ₇	NSK ₆	NSK ₅	NSK ₄	NSK ₃	NSK ₂	NSK ₁
SLN _S	SLN ₁₅	SLN ₁₄	SLN ₁₃	SLN ₁₂	SLN ₁₁	SLN ₁₀	SLN ₉
SLN ₈	SLN ₇	SLN ₆	SLN ₅	SLN ₄	SLN ₃	SLN ₂	SLN ₁
SNF _S	SNF ₁₅	SNF ₁₄	SNF ₁₃	SNF ₁₂	SNF ₁₁	SNF ₁₀	SNF ₉
SNF ₈	SNF ₇	SNF ₆	SNF ₅	SNF ₄	SNF ₃	SNF ₂	SNF ₁
NSK ₁₆	NSK ₁₅	NSK ₁₄	NSK ₁₃	NSK ₁₂	NSK ₁₁	NSK ₁₀	NSK ₉
NSK ₈	NSK ₇	NSK ₆	NSK ₅	NSK ₄	NSK ₃	NSK ₂	NSK ₁
SLN _S	SLN ₁₅	SLN ₁₄	SLN ₁₃	SLN ₁₂	SLN ₁₁	SLN ₁₀	SLN ₉
SLN ₈	SLN ₇	SLN ₆	SLN ₅	SLN ₄	SLN ₃	SLN ₂	SLN ₁
SNF _S	SNF ₁₅	SNF ₁₄	SNF ₁₃	SNF ₁₂	SNF ₁₁	SNF ₁₀	SNF ₉
SNF ₈	SNF ₇	SNF ₆	SNF ₅	SNF ₄	SNF ₃	SNF ₂	SNF ₁
NSK ₁₆	NSK ₁₅	NSK ₁₄	NSK ₁₃	NSK ₁₂	NSK ₁₁	NSK ₁₀	NSK ₉
NSK ₈	NSK ₇	NSK ₆	NSK ₅	NSK ₄	NSK ₃	NSK ₂	NSK ₁
SLN _S	SLN ₁₅	SLN ₁₄	SLN ₁₃	SLN ₁₂	SLN ₁₁	SLN ₁₀	SLN ₉
SLN ₈	SLN ₇	SLN ₆	SLN ₅	SLN ₄	SLN ₃	SLN ₂	SLN ₁
SNF _S	SNF ₁₅	SNF ₁₄	SNF ₁₃	SNF ₁₂	SNF ₁₁	SNF ₁₀	SNF ₉
SNF ₈	SNF ₇	SNF ₆	SNF ₅	SNF ₄	SNF ₃	SNF ₂	SNF ₁
NSK ₁₆	NSK ₁₅	NSK ₁₄	NSK ₁₃	NSK ₁₂	NSK ₁₁	NSK ₁₀	NSK ₉
NSK ₈	NSK ₇	NSK ₆	NSK ₅	NSK ₄	NSK ₃	NSK ₂	NSK ₁

- 1 NSR Number of skips remaining, including the ones in this block (1-50).
- 2
- 3 SLN Line number of skip gap (two's complement, signed binary) (-32000 to +32000).
- 4 SNF First muted station in skip gap (two's complement, signed binary) (-32000 to +32000). This is the first station from which no data was collected.
- 5
- 6 NSK Number of stations in skip gap (1-999).
- 7
- 8
- 9
- 10
- 11
- 12
- 13
- 14
- 15
- 16
- 17
- 18
- 19
- 20
- 21
- 22
- 23
- 24
- 25
- 26
- 27
- 28
- 29
- 30
- 31
- 32

SKIPS HEADER

5. EXTERNAL HEADER

The external header is used to record additional user supplied data. Up to 3168 bytes (99 blocks times 32 bytes per block) of data can be accommodated. The format of the data in these blocks is specified by the individual user.

6. DATA BLOCK

Each trace is recorded as a trace header, which identifies the individual trace, followed by the trace data. Each trace is separated from other traces by a standard interblock gap. Auxillary channels are recorded first, followed by seis channels.

Trace data in the I/O Systems may be recorded in one of three formats: 20-bit binary demultiplexed (SEG-D 8015), 32-bit hexadecimal demultiplexed (SEG-D 8048), or 32-bit IEEE demultiplexed (SEG-D 8058).

6.1 TRACE HEADER

Each trace header is 20 bytes long and contains identifying data for that trace.

0	1	2	3	4	5	6	7
F ₁	F ₁	F ₁	F ₁	F ₂	F ₂	F ₂	F ₂
F ₃	F ₃	F ₃	F ₃	F ₄	F ₄	F ₄	F ₄
ST ₁	ST ₁	ST ₁	ST ₁	ST ₂	ST ₂	ST ₂	ST ₂
CN ₁	CN ₁	CN ₁	CN ₁	CN ₂	CN ₂	CN ₂	CN ₂
TN ₁	TN ₁	TN ₁	TN ₁	TN ₂	TN ₂	TN ₂	TN ₂
TN ₃	TN ₃	TN ₃	TN ₃	TN ₄	TN ₄	TN ₄	TN ₄
T _S	T ₁₄	T ₁₃	T ₁₂	T ₁₁	T ₁₀	T ₉	T ₈
T ₇	T ₆	T ₅	T ₄	T ₃	T ₂	T ₁	T ₀
T ₋₁	T ₋₂	T ₋₃	T ₋₄	T ₋₅	T ₋₆	T ₋₇	T ₋₈
0	0	0	0	0	0	0	0
SS ₋₁	SS ₋₂	SS ₋₃	SS ₋₄	SS ₋₅	SS ₋₆	SS ₋₇	SS ₋₈
SNS ₈	SNS ₇	SNS ₆	SNS ₅	SNS ₄	SNS ₃	SNS ₂	SNS ₁
TW ₁₅	TW ₁₄	TW ₁₃	TW ₁₂	TW ₁₁	TW ₁₀	TW ₉	TW ₈
TW ₇	TW ₆	TW ₅	TW ₄	TW ₃	TW ₂	TW ₁	TW ₀
TW ₋₁	TW ₋₂	TW ₋₃	TW ₋₄	TW ₋₅	TW ₋₆	TW ₋₇	TW ₋₈
0	0	0	0	0	0	0	0
0	0	0	0	0	0	0	0
0	0	0	0	0	0	0	0
0	0	0	0	0	0	0	0
0	0	0	0	0	0	0	0

- 1 F File number (0-9999).
- 2 ST Scan type number. Always 1.
- 3 CN Channel set number (1-99).
- 4 TN Channel or trace number in the channel set.
- 5 T First timing word (milliseconds). This is a 3-byte, sign and magnitude, binary number that has the LSB (T₈) equal to 1/256 msec. In synchronous time break mode, this will always be 0. In asynchronous time break mode and slave operation, this is the time from the energy source event to the system timing interval at which acquisition started.
- 6
- 7
- 8
- 9 SS Sample skew. Always 0.
- 10 SNS Sensor type. Valid values:
 - 80h Pressure phone (hydrophone)
 - 40h Velocity phone (geophone)
 - C0h Other
 - 00h Unknown
- 11
- 12
- 13 TW Time break window end (milliseconds). This is a 3-byte positive binary number that has the LSB (TW₈) equal to 1/256 msec. This is the time from time break to the end of the time break window. If this value is 0, the time break window expired and recording started at the end of the time break window.
- 14
- 15
- 16
- 17
- 18
- 19
- 20

TRACE HEADER

6.2 DATA BLOCK 2½ BYTE

In this format, numbers are expressed as:
 $(-1)^{\text{SIGN}} \times 2^{\text{EXPONENT}} \times 0.\text{FRACTION}$.

The SEG-D 8015 format is a 10 byte long pattern, containing four 20 bit values, that repeats until all samples are listed.

0	1	2	3	4	5	6	7
C ₃	C ₂	C ₁	C ₀	C ₃	C ₂	C ₁	C ₀
C ₃	C ₂	C ₁	C ₀	C ₃	C ₂	C ₁	C ₀
S	Q ₋₁	Q ₋₂	Q ₋₃	Q ₋₄	Q ₋₅	Q ₋₆	Q ₋₇
Q ₋₈	Q ₋₉	Q ₋₁₀	Q ₋₁₁	Q ₋₁₂	Q ₋₁₃	Q ₋₁₄	Q ₋₁₅
S	Q ₋₁	Q ₋₂	Q ₋₃	Q ₋₄	Q ₋₅	Q ₋₆	Q ₋₇
Q ₋₈	Q ₋₉	Q ₋₁₀	Q ₋₁₁	Q ₋₁₂	Q ₋₁₃	Q ₋₁₄	Q ₋₁₅
S	Q ₋₁	Q ₋₂	Q ₋₃	Q ₋₄	Q ₋₅	Q ₋₆	Q ₋₇
Q ₋₈	Q ₋₉	Q ₋₁₀	Q ₋₁₁	Q ₋₁₂	Q ₋₁₃	Q ₋₁₄	Q ₋₁₅
S	Q ₋₁	Q ₋₂	Q ₋₃	Q ₋₄	Q ₋₅	Q ₋₆	Q ₋₇
Q ₋₈	Q ₋₉	Q ₋₁₀	Q ₋₁₁	Q ₋₁₂	Q ₋₁₃	Q ₋₁₄	Q ₋₁₅

- 1 C Positive binary exponent of 2.
- 2 S Sign: 0 = positive, 1 = negative.
- 3 Q 15 bit one's complement binary fraction with radix point to the left of the most significant digit with the MSB defined as 2⁻¹.
- 4
- 5 Bytes 1 and 2 contain the 4-bit exponents for the following four samples. Bytes 3 and 4 are the fraction for sample 1; bytes 5 and 6, the fraction for sample 2; bytes 7 and 8, the fraction for sample 3; and bytes 9 and 10, the fraction for sample 4.
- 6
- 7
- 8
- 9
- 10

**DATA BLOCK 2½ BYTE
SEG-D 8015**

6.3 DATA BLOCK 4 BYTE

In 4 Byte format, numbers are expressed as:
 $(-1)^{\text{SIGN}} \times 16^{\text{EXPONENT}-64} \times 0.\text{FRACTION}$.

The SEG-D 8048 format is a four byte long pattern that repeats until all samples are listed.

0	1	2	3	4	5	6	7
S	C ₆	C ₅	C ₄	C ₃	C ₂	C ₁	C ₀
Q ₋₁	Q ₋₂	Q ₋₃	Q ₋₄	Q ₋₅	Q ₋₆	Q ₋₇	Q ₋₈
Q ₋₉	Q ₋₁₀	Q ₋₁₁	Q ₋₁₂	Q ₋₁₃	Q ₋₁₄	Q ₋₁₅	Q ₋₁₆
Q ₋₁₇	Q ₋₁₈	Q ₋₁₉	Q ₋₂₀	Q ₋₂₁	Q ₋₂₂	Q ₋₂₃	0

- 1 S Sign: 0 = positive, 1 = negative.
- 2 C Positive binary exponent of 16. It is biased by 64.
- 3 Q 23 bit positive binary fraction with radix point to the left of the most significant digit with the MSB defined as 2⁻¹.
- 4

**DATA BLOCK 4 BYTE
SEG-D 8048**

6.4 DATA BLOCK IEEE

If both exponent and fraction are 0, then value is 0.

The SEG-D 8058 format is a four byte long pattern that repeats until all samples are listed.

The IEEE format is documented in the IEEE standard, IEEE/ANSI Std 754-1985. Denormalized number, overflow, and not a number conditions are outside the range of data values produced in I/O Data Acquisition Systems and should not appear in the tape record.

In IEEE format, normalized numbers are expressed as:
 $(-1)^{\text{SIGN}} \times 2^{\text{EXPONENT}-127} \times (1).\text{FRACTION}$.

0	1	2	3	4	5	6	7
S	C ₇	C ₆	C ₅	C ₄	C ₃	C ₂	C ₁
C ₀	Q ₋₁	Q ₋₂	Q ₋₃	Q ₋₄	Q ₋₅	Q ₋₆	Q ₋₇
Q ₋₈	Q ₋₉	Q ₋₁₀	Q ₋₁₁	Q ₋₁₂	Q ₋₁₃	Q ₋₁₄	Q ₋₁₅
Q ₋₁₆	Q ₋₁₇	Q ₋₁₈	Q ₋₁₉	Q ₋₂₀	Q ₋₂₁	Q ₋₂₂	Q ₋₂₃

- 1 S Sign: 0 = positive, 1 = negative.
- 2 C Positive binary exponent of 2. It is biased by 127.
- 3 Q 23 bit positive binary fraction with radix point to the left of the most significant digit with the MSB defined as 2⁻¹.
- 4

**DATA BLOCK IEEE
SEG-D 8058**

7. DESCALE MULTIPLIER

The digital data word recorded to tape represents the input to the analog-to-digital converter. The effects of the preamplifier gain, the correlator manual scale factor, and the data conversion gain in the 2^{1/2} byte format must be subtracted from the recorded value to obtain the equivalent input signal.

The descale multiplier (MP) is used to convert the digital data word recorded on tape into millivolts of signal at the input to the seismic data acquisition system. The MP is an 8 bit word which can range in value from +31.75 to -31.75. The MP value is found in byte 8 of each channel set descriptor in the scan type header.

MSB	MP _S	MP ₄	MP ₃	MP ₂	MP ₁	MP ₀	MP ₋₁	MP ₋₂	LSB
	sign	2 ⁴ 16	2 ³ 8	2 ² 4	2 ¹ 2	2 ⁰ 1	2 ⁻¹ 1/2	2 ⁻² 1/4	

DESCALE MULTIPLIER (MP)

For the 2^{1/2} byte format, MP is defined by the equation: $MP = FS - PA - CMAX$. The maximum value recorded to tape in this format is 2¹⁵-1, so there is a conversion gain of 2¹⁵ which must be accounted for. Therefore, CMAX = 15.

For the 4 byte and IEEE formats, MP is defined by the equation: $MP = FS - PA - 4(CMAX - 64)$. The maximum value recorded to tape in these formats is 1, so there is no conversion gain in either format. Therefore, for these formats CMAX = 64 and, effectively, $MP = FS - PA$.

FS is the exponent of two corresponding to the full scale of the converter. For seis channels, FS = 13 for all formats. For auxillary channels, FS is channel dependent. For the four filtered auxillary pilot channels, FS = 13.5. For the seven unfiltered channels, FS = 14. For the 100 Hz time signal, FS = 12.25.

PA is the exponent of two defined by the preamplifier gain. PA relates to K-gain as follows: for 12 dB K-gain, PA = 2; for 24 dB K-gain, PA = 4; for 36 dB K-gain, PA = 6; for 48 dB K-gain, PA = 8.

Each 1.5 dB step in auxillary amplifier gain corresponds to a .25 change in the descale multiplier. For the four filtered auxillary channels (-24 to 22.5dB gain), PA will range from -4 to 3.75. For the unfiltered auxillary channels (0 to 46.5dB gain), PA will range from 0 to 7.75.

For correlated data, the descale multiplier will include the effect of the manual scale factor. For example, an uncorrelated record of data acquired at 48 dB K-gain will have MP = 5 (14h) in the IEEE format. A record of correlated data acquired with 48 dB K-gain and a manual scale factor of 36 dB (the default value) will have MP = -1 (84h) in the IEEE format.

7.1 MP IN THE 2^{1/2} BYTE FORMAT

Input signal = (-1)^S x 0.QQQQ QQQQ QQQQ QQQ x 2^{CCCC} x 2^{MP} millivolts where 2^{MP} is the value required to descale the data word to the recording system input level. Since the fraction is in one's complement format, if S=1 then the fraction must first be inverted, bit by bit, before performing the multiplication.

7.2 MP IN THE 4 BYTE FORMAT

Input signal = (-1)^S x 0.QQQQ QQQQ QQQQ QQQQ QQQQ QQQ x 16^{CCCCCCC-64} x 2^{MP} millivolts where 2^{MP} is the value required to descale the data word to the recording system input level.

7.3 MP IN THE IEEE FORMAT

Input signal = (-1)^S x (1).QQQQ QQQQ QQQQ QQQQ QQQQ QQQ x 2^{CCCCCCC-127} x 2^{MP} millivolts where 2^{MP} is the value required to descale the data word to the recording system input level. If QQQQQQQQQQQQQQQQQQQQQ=0 and CCCCCC=0, then the input signal is 0 volts.

8. HPE NOTCH

The base frequency, harmonic multiplier, and notch bandwidth can be computed from values stored in ancillary data block header 1. For powerline mode, HPES contains the HPE base frequency (in microhertz), MXA through MXE the harmonic multiplier (times six), and NWA through NWE the lambda value used to calculate the bandwidth. For special fixed frequency mode, HPFA through HPFE contain the notch frequencies (in hundredths of hertz) and NWA through NWE the lambda value.

8.1 NOTCH EQUATIONS IN I/O SYSTEM ONE

In the I/O SYSTEM ONE the following formulas are used to find the amplitude and phase of the notch frequencies:

Amplitude (in dB) = $20 \log_{10} (| H(\omega) |) = 20 \log_{10} (\text{sqrt} ((A^2 + B^2) / (C^2 + D^2)))$
 Phase (in radians) = $\text{arg} (H(\omega)) = \text{arctan}(B/A) - \text{arctan}(D/C)$

Where: $A = \cos 3\omega - (2\cos 2\omega \times \cos \omega_\phi) + \cos \omega$
 $B = \sin 3\omega - (2\sin 2\omega \times \cos \omega_\phi) + \sin \omega$
 $C = \cos 3\omega - (2\cos 2\omega \times \cos \omega_\phi) + (K \times \cos \omega \times \cos \omega_\phi) + \cos \omega - K$
 $D = \sin 3\omega - (2\sin 2\omega \times \cos \omega_\phi) + (K \times \sin \omega \times \cos \omega_\phi) + \sin \omega$

Where: $\omega = 2\pi f t = (0.001\pi)f$
 $\omega_\phi = 2\pi f_\phi t = (0.001\pi)f_\phi$
 $K = (0.00003125977)f_\phi \times J$

Where: $t = \text{sample interval} = 0.5\text{ms}$ (I/O SYSTEM ONE HPE always operates at 0.5ms)
 $f_\phi = \text{notch center frequency}$ HPES \times MXn from tape
 $J = \text{notch bandwidth percentage}$ NWN / (1.067 \times f_ϕ) from tape

To maintain the correct quadrant information for the phase data it is necessary to ascertain the signs of the functions A, B, C, and D before performing the arctan function. Once the arctan function is performed, the angle can then be corrected in the following manner:

+A and +B	angle = arctan B/A	+C and +D	angle = arctan C/D
+A and -B	angle = $2\pi - \text{arctan} B/A $	+C and -D	angle = $2\pi - \text{arctan} C/D $
-A and +B	angle = $\pi - \text{arctan} B/A $	-C and +D	angle = $\pi - \text{arctan} C/D $
-A and -B	angle = $\pi + \text{arctan} B/A $	-C and -D	angle = $\pi + \text{arctan} C/D $

8.2 NOTCH EQUATIONS IN I/O SYSTEM TWO

In the I/O SYSTEM TWO the following formulas are used to find the amplitude and phase of the notch frequencies:

Amplitude (in dB) = $20 \log_{10} | H(z) |$
 Phase (in radians) = $\text{arg} (H(z))$

Where: $H(z) = ((z^2 + a_1z + a_2) / (z^2 + b_1z + b_2)) \times (1 - \mu) = \text{transfer function}$

Where: $z = e^{2i\pi f T}$
 $a_1 = -2 \times \cos \omega_\phi$
 $a_2 = 1$
 $b_1 = -2(1 - \mu) \times \cos \omega_\phi$
 $b_2 = 1 - 2\mu$

Where: $\omega_\phi = 2\pi f_\phi T = \text{notch center frequency}$
 $\mu = 2000\lambda T / 65536$

Where: $f_\phi = \text{center frequency}$ either HPES \times MXn or HPFn from tape
 $\lambda = \text{lambda value}$ NWN from tape
 $T = \text{sample interval (in seconds)}$

9. FORMAT CONVERSION LOSSES (SEG-D IEEE vs. SEG-D 4-BYTE)

The SEG-D IEEE 32-bit floating point format will exactly represent all possible output values generated by a 24 bit analog to digital converter. There is a loss of information when the SEG-D 4-Byte format is used. This is due to the conversion from IEEE 32-bit floating point format, used internally in the I/O Data Acquisition Systems, to the SEG-D 4-BYTE format.

In IEEE format, numbers are expressed as $(-1)^{\text{sign}} \times 2^{\text{exponent}-127} \times (1).\text{23-bit fraction}$.

In 4-Byte format, numbers are expressed as $(-1)^{\text{sign}} \times 16^{\text{exponent}-64} \times (0).\text{23-bit fraction}$.

To see the conversion losses, let us compare the differences between formats when we have a value of .0625.

In IEEE .0625 equals 3D800000h as follows:

sign is 0
 exponent is 123 (i.e., 2^{-4})
 fraction is (1).0000 0000 0000 0000 0000 000

In 4-Byte format .0625 equals 40100000h as follows

sign is 0
 exponent is 64 (i.e., 16^0)
 fraction is (0).0001 0000 0000 0000 0000 000

If we increase the IEEE number by one bit in the least significant position to 3D800001h, the number in 4-byte format remains 40100000h. That is:

IEEE fraction is (1).0000 0000 0000 0000 0000 001
 4-Byte fraction is (0).0001 0000 0000 0000 0000 000 001.

If we increase the 4-byte number by one bit in the least significant position to 40100002h, the same number in IEEE format becomes 3D800010h. That is:

4-Byte fraction is (0).0001 0000 0000 0000 0000 001
 IEEE fraction is (1).0000 0000 0000 0000 0010 000.

In this case, there are 15 values that can be expressed in the IEEE format that cannot accurately be expressed in the 4-Byte format. There will always be a 1 to 4 bit loss when converting IEEE floating point numbers to the SEG-D 4-Byte format.

10. CHANNEL SET DESCRIPTORS IN I/O SYSTEMS

In the I/O Data Acquisition Systems, data is recorded by channel set. A channel set is defined as a group of channels that are all recorded with identical recording parameters. Recorded traces are identified by their channel set number and their position (number) within the channel set. In the original SEG-D format the maximum number of channel sets is 99.

10.1 SCAN TYPE HEADER

The scan type header is used to describe the information of the recorded channels (filters, sampling intervals, sample skew, etc.). SEG-D documentation says that the scan type header is composed of one or more channel set descriptors followed by skew information. In I/O Systems, all data is collected at the same sample rate with the same number of samples, all field channels have the same filter and notch settings, and there is no sample skew. Therefore, in I/O Systems the scan type header is simply a list of channel sets.

Since I/O Systems support a more complex filter setup than the original SEG-D format, low cut filter frequency and slope and notch filter frequencies are set to 0 in the scan type header and their actual values are encoded in the ancillary header block of the extended header.

10.2 NUMBER OF CHANNEL SETS

Byte 29 of the general header will contain the total number of channel sets. Auxillary data is recorded first, followed by the seismic traces. For auxillary channels, the system will record each active channel as an individual channel set. For field data, the only parameter that may change between channels is the preamplifier K-gain. Therefore, if circular K-gains are used there will be more than one channel set. If zeroed data is recorded on tape for the energy gap and skip gaps, each gap will be a channel set. Since channels sets contain consecutive receiver line stations, if there are energy or skip gaps of one or more stations, regardless of whether the data is zeroed or muted, there will be more than one channel set.

10.3 AUXILLARY CHANNELS

Bytes 11, 12, and 13 of the extended general header will contain the number (BCD) of active auxillary channels and the first and last auxillary channel set numbers. For auxillary channels, bytes 9 and 10 of the scan type header will contain a BCD value of 0001 indicating 1 channel per channel set. The lower 4 bits of byte 11 of the scan type header will contain a value indicating the channel type.

For Vibroseis, the pilot signals will always have the same low cut filter and antialias settings as the field; the designations of filtered and unfiltered refer only to spectral shaping and notch filters. That is, an unfiltered pilot will have the same low cut and antialias filtering as the seismic data, but it will not have either notch or spectral shaping filters applied, even if the seismic channels do. A filtered pilot will, in addition to the low cut and antialias filters, have the same notch and spectral shaping filters as the seismic channels. (If the scan type header indicates a filtered pilot, but the ancillary data header shows no spectral shaping or notch filters, then there was no spectral shaping or notch filtering applied to the pilot channel.)

10.4 SEISMIC TRACES

For seismic data, the traces are recorded starting with the lowest numbered station on the lowest numbered line and continue, line by line, until the highest numbered station on the highest numbered line is reached. If the same preamplifier K-gain is applied at the end of one line and the beginning of the next line, the channel set will extend onto the next line.

Subtracting the binary value in byte 11 of the extended general header from the BCD value in byte 29 of the general header will obtain the number of channel sets containing field data. If this number is more than one, then the line descriptor header and the skips header must be decoded to determine which channels within the channel sets correspond to which receiver line and station numbers. The first channel set of seismic data will start at the first station on the lowest line recorded.

10.5 ENERGY AND SKIP GAPS

If an energy gap is used and the data is muted (not recorded), then the line descriptor header will contain a description of the energy gap. If zeroed data is being recorded for the energy gap, then the line descriptor header will not indicate an energy gap but there will be channel sets whose channel type indicates unused. If a skip gap results in muted or zeroed data, the same applies: the skips header will indicate channels for which no data was recorded, or channel sets of unused (zeroed) data will be recorded. If there is a skip gap to route the seismic line around an obstacle but no receiver stations are lost, then this will not affect the channel sets.